

HRODC Ltd.

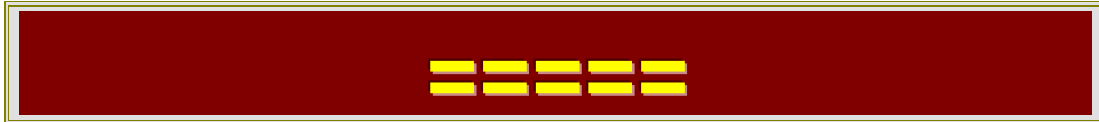

HRODC Ltd QUOTATION



With Kindest Regards,

A stylized, handwritten signature in gold ink, appearing to read "R. B. Crawford".

Prof. Dr. R. B. Crawford
Chief Executive



Human Resource and Organisational Development Consultancy (HRODC) Ltd. Registered in England No. 6088763.

Registered Office: 122A Bhylls Lane, Castlecroft, Wolverhampton, West Midlands WV3 8DZ, UK

Prof. Dr. R. B. Crawford

PhD (London), MEd.M. (Bath), Adv. Dip. Ed. (Bristol), PGCIS (TVU), ITC (UWI), MAAM, MAOM, LESAN, MISGS. Visiting Prof. P.U.P.
Chief Executive & Chief Consultant – HRODC Ltd.



V.A.T. # 8958 765 38

	<h1>HRODC Ltd.</h1>	
<p>122A Bhylls Lane, Wolverhampton, WV3 8DZ, UK Telephone: +44 (0) 1902 763 607 +44 (0) 1902 569133 Mobile: +44 (0) 7736 147507 E-mail: consult@hrod-consultancy.com sales@hrod-consultancy.com Website http://www.hrod-consultancy.com</p>		<p>328 Linen Hall, 162-168 Regent Street, London. W1B 5TD, UK Tel: +44 (0) 20 84809628 Mobile: +44 (0) 7736 147507 E-mail: consult@hrod-consultancy.com sales@hrod-consultancy.com Website http://www.hrod-consultancy.com</p>
<h2>Human Resource and Organisational Development Consultancy (HRODC) Ltd.</h2>		

HRODC Ltd QUOTATION

To:	
Quotation #	
Req. Ref.	NA
Date Issued:	
Validity Period:	30 Days
Prepared By:	Prof. Dr. R. B. Crawford
Number of Pages:	9

HRODC Ltd – Legal Parameter

Human Resource and Organisational Development Consultancy (HRODC) Ltd is Registered in England, with Registration Number 6088763. Its VAT Registration is: 8958 765 38. It is directly accountable to, and monitored by, several government agencies, including Companies House, an Executive Agency of the Department for Business, Enterprise and Regulatory Reform (BERR). All 'Offices' of HRODC Ltd, including National Representatives are subject to public scrutiny and transparency. Its Registered Office is 122A Bhylls Lane, Castlecroft, Wolverhampton, West Midlands WV3 8DZ, UK, with Office in London UK. It has National Representatives in Nigeria, Ghana, Cameroon, United Arab Emirates (UAE), Kingdom of Saudi Arabia, among others. Prof. Dr. R. B. Crawford, PhD (London), MEd.M. (Bath), Adv. Dip. Ed. (Bristol), PGCIS (TVU), ITC (UWI), MAAM, MAOM, LESAN, MISGS. Visiting Prof. P.U.P. is its Chief Executive.

Human Resource and Organisational Development Consultancy (HRODC) Ltd. Registered in England No. 6088763. 2

Registered Office: 122A Bhylls Lane, Castlecroft, Wolverhampton, West Midlands WV3 8DZ, UK

Prof. Dr. R. B. Crawford

PhD (London), MEd.M. (Bath), Adv. Dip. Ed. (Bristol), PGCIS (TVU), ITC (UWI), MAAM, MAOM, LESAN, MISGS. Visiting Prof. P.U.P.
Chief Executive & Chief Consultant – HRODC Ltd.



V.A.T. # 8958 765 38

Machine Quotation

Column Number						
Row No.	1	2	3	4	5	6
	Product or Service	Product/ Service #	Short Description	Quantity	Unit Price US\$	Total Cost in US\$
1.	Transporter	HRODC_UT1	HRODC_UT1 Urban Transporter – Bus – Coach Transporter	1	\$87,000.00	\$87,000.00
2.						
Subtotal		Free International Port-To-Port Delivery				
Delivery		To be advised				
V.A.T. @		Europeans Only				
Grand Total						
Payment Terms		<ol style="list-style-type: none"> 1. The prices, above, exclude delivery, installation and training, unless otherwise stated. These costs will be advised at your request. 2. Products costing in excess of us US\$40,000.00 require a deposit of 50% by Telegraphic Transfer (TT) or bank counter credit, at the time of order. The remaining 50%, by Irrevocable Letter of Credit (ILC), is required one week before shipment of the complete item. 3. 100% of the cost of items of up to \$40,000.00 is required at the time of order. 4. Bank details for payment, and extended terms, where applicable, will be included in the Proforma Invoice, following the confirmation of your order. 				

Human Resource and Organisational Development Consultancy (HRODC) Ltd. Registered in England No. 6088763. 3

Registered Office: 122A Bhylls Lane, Castlecroft, Wolverhampton, West Midlands WV3 8DZ, UK

Prof. Dr. R. B. Crawford

PhD (London), MEd.M. (Bath), Adv. Dip. Ed. (Bristol), PGCIS (TVU), ITC (UWI), MAAM, MAOM, LESAN, MISGS. Visiting Prof. P.U.P.
Chief Executive & Chief Consultant – HRODC Ltd.



V.A.T. # 8958 765 38

Product Description

Start of Urban Bus Coach Transporter Description

People Transporter – HRODC_UT1 People Transporter



Wheel base (mm)		5650+1450
Curb weight (kg)		11650
Upper body Dimension(Lx W x H)		9500x2100x1450
Engine	Model	WD615.50(BASSED on Styre Technology)
	Power, max (kw/rpm)	206/2200
	Max torque	1160/1100-1600
	Emission standard	EUROII
Fuel Tank Volume		400 Liters
Clutch	Model	GFX420, Single dry frictional disc, Hydraulic boosting
Gearbox	Model	ZF5S-111GP - ZF 9 forward gears, 1 reverse gear, manual.
Brake system	Service brake	Brake gap can be adjusted automatically, double circulation air brake system
	Assistant brake	Engine exhaust brake

Human Resource and Organisational Development Consultancy (HRODC) Ltd. Registered in England No. 6088763. 4

Registered Office: 122A Bhylls Lane, Castlecroft, Wolverhampton, West Midlands WV3 8DZ, UK

Prof. Dr. R. B. Crawford

PhD (London), MEd.M. (Bath), Adv. Dip. Ed. (Bristol), PGCIS (TVU), ITC (UWI), MAAM, MAOM, LESAN, MISGS. Visiting Prof. P.U.P.
Chief Executive & Chief Consultant – HRODC Ltd.



V.A.T. # 8958 765 38

People Transporter – HRODC_UT1 People Transporter		
	Park brake	Potential springs pressing on middle and rear wheels
Steering system	Model	TAS85, whole circulation in ball type, hydraulic boosting
Frame	Fish belly shape, variable width, variable sections	
Front axle (Mercedes Benz Technology)	Double-shoe pneumatic brake, non-driving steering axle	
Middle and Rear axle (Mercedes Benz Technology)	Double-shoe pneumatic brake, ductile casting casing, with hub redactor, double reduction driving axle	
Tire	12.00R20	
Electrical system	Battery	2X12V/135Ah
	Generator	28V-35A
	Starter	5.4Kw/24V
Cab	short cab, full steel skeleton structure, covered with double layer steel plate; can be tipped forward;	



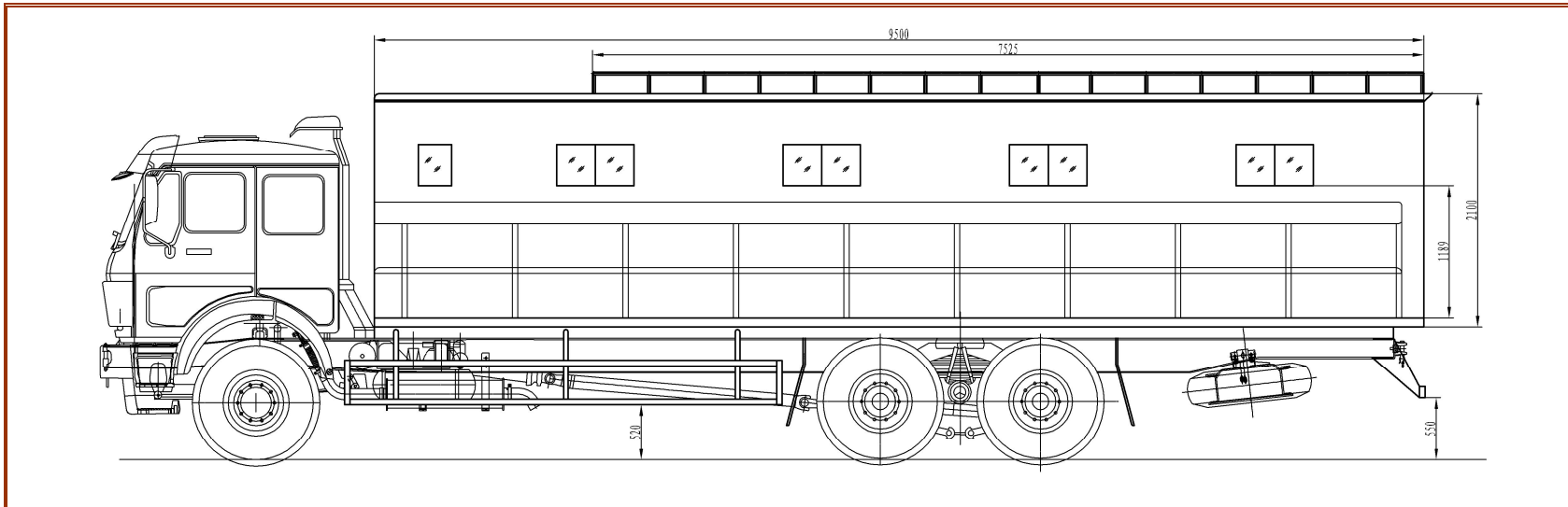

The left side view of the coach is shown as the above Figure:

1. 4 openable sliding windows and 1 non-openable window, 1189 mm distance from the lowest edge of window to the floor.
2. The sliding window can be opened by drawing and pulling.
3. The window body is made of high quality toughened glass.
4. The coach top is designed with rectangular rails 7525×2290.
5. The fender guards are located at the left, right and rear side of the coach. The left and right fender guards are 520 mm distance from the ground, and the rear fender guards are 50 mm distance from the ground.

Human Resource and Organisational Development Consultancy (HRODC) Ltd. Registered in England No. 6088763.

Registered Office: 122A Bhylls Lane, Castlecroft, Wolverhampton, West Midlands WV3 8DZ, UK

Prof. Dr. R. B. Crawford

PhD (London), MEd.M. (Bath), Adv. Dip. Ed. (Bristol), PGCIS (TVU), ITC (UWI), MAAM, MAOM, LESAN, MISGS. Visiting Prof. P.U.P.

Chief Executive & Chief Consultant – HRODC Ltd.



V.A.T. # 8958 765 38

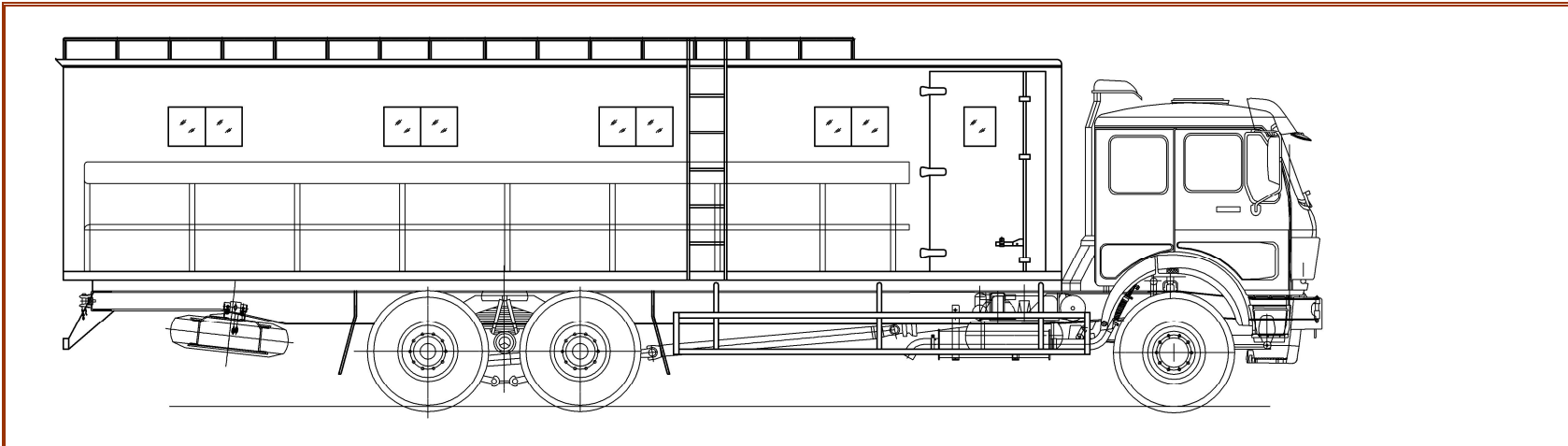

The right side view of the coach is shown in the above Figure, consisting of:

1. 4 openable sliding windows and 1 entrance door, 1189mm distance from the lowest edge of the window to the coach floor.
2. The sliding window can be opened by drawing and pulling.
3. The size of entrance door: 2230×1105, 1 non-openable window is designed on the door, and the door can be only opened toward the reverse direction of travel. The entrance door uses the container-door lock for locking, which is opened only at outside of the coach.
4. The windows are made of high quality toughened glass.

The coach is equipped with the fixed roof access ladder for personnel accessing the coach top



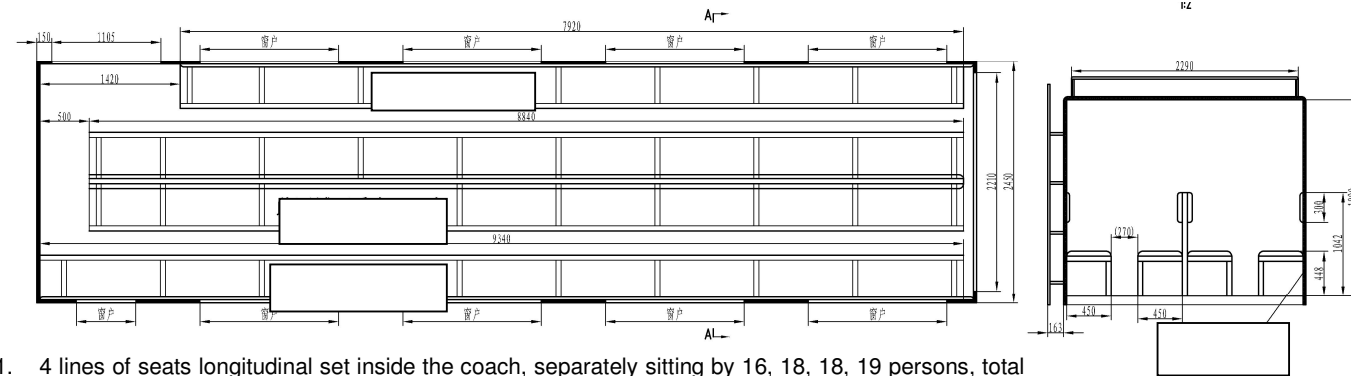

The inside of the coach. Details of arrangement of seats.

1. 4 lines of seats longitudinal set inside the coach, separately sitting by 16, 18, 18, 19 persons, total sitting for 71 persons.
2. The far-front section is designed with personnel walkway, which is convenient for personnel entering the coach from left front door.
3. The floor is designed with high quality checkered steel plate, which can protect person from slip.
4. The seat and backrest are made of high quality prefabricated leather, with perfect appearance and easy maintenance. The seat and backrest are connected by bolts, which is easy to be removed.
5. The coach body is designed with 30mm insulation layer
6. The outer and inner skins are both made of coloured steel plate.

The tail layout of the coach is shown as the right Figure:

1. Double wing door, 1 non-openable window on the door body. The double wing door uses container-door lock for locking, which is opened only at outside of the coach.
2. The windows are made of high quality toughened glass.

Optional equipments:

1. Entrance ladders for every entrance door, one on the right side, two on the rear.
2. One skylight on the front section of coach body, openable during travelling.

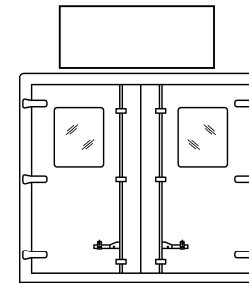

End of Urban Bus Coach Transporter Description

Additional Comments

Please note that we are actively engaged in research and development. Consequently, our product description, specification and aesthetic features are constantly changing so as to improve the quality and physical appearance of the products to our clients. Consequently, we might vary the characteristics of the above products, without notice.

With Kindest Regards,



Prof. Dr. R. B. Crawford
Chief Executive



Human Resource and Organisational Development Consultancy (HRODC) Ltd. Registered in England No. 6088763.

Registered Office: 122A Bhylls Lane, Castlecroft, Wolverhampton, West Midlands WV3 8DZ, UK

Prof. Dr. R. B. Crawford

PhD (London), MEd.M. (Bath), Adv. Dip. Ed. (Bristol), PGCIS (TVU), ITC (UWI), MAAM, MAOM, LESAN, MISGS. Visiting Prof. P.U.P.
Chief Executive & Chief Consultant – HRODC Ltd.



V.A.T. # 8958 765 38